

CKBB1840

Fast charge

1300F



GPS 跟踪/RF 和通信电源

- ❖ NB IOT/Pulse power supply
NB 通信/脉冲功率电源
- ❖ Electric Tool/ETC/Quick Charge power
电动工具/ETC 及其它快充电源
- ❖ Power industry
电力行业
- ❖ Electronic cigarettes
电子烟市场

Product structure 产品结构

Lithium-ion capacitor is a hybrid capacitor, Jinpei gets an unique cutting-edge technology in the field. It has a larger energy density than supercapacitors and a smaller volume; Compared with lithium-ion batteries, the power density is large, the charging speed is faster, the temperature range is wide, and the life is longer.

锂离子电容器是一种混合型电容器，金沛在此领域用于独特的前沿技术。它具有比超级电容器能量密度大体积小；比锂离子电池功率密度大，充电速度更快，温度范围广，寿命更长等优点

This product is a radial cell with the parallel of electric double-layer capacitor + lithium ion battery. It consists of two electrodes, an insulation separator and electrolyte filled in the cell. Rubber stoppers are used to seal the aluminum case, with two radials located on the top.

本产品为引线型单体，基于双电层电容器+锂离子电池内部“并联”的新型储能器件，两极间用隔膜隔开，电解液填充于单元内部空间，用橡胶塞对铝外壳进行密封，两极的引线端子位于产品顶端。

Aluminum shell—Sealed core system to prevent electrolyte leakage.

铝壳—密封电芯体系，防止电解液泄露。

Electrode—Key material for energy storage, consisting of a cathode providing a lithium source and a carbon anode.

电极—储能关键材料，由提供锂源的阴极和碳阳极构成。

Diaphragm—Isolates positive and negative poles, preventing short circuit caused by contact between two poles. The diaphragm has the function of allowing the passage of electrolyte ions.

隔膜—隔离正负极，防止两极接触而短路。具有能使电解质离子通过的功能。

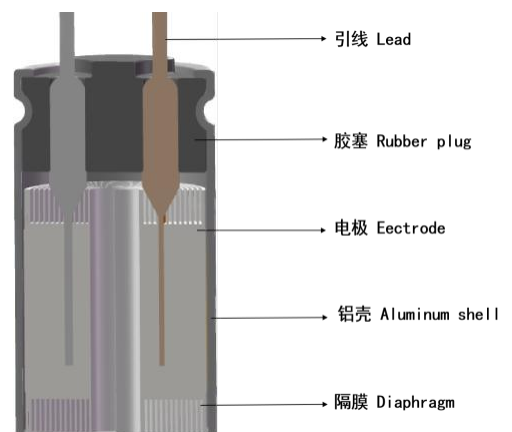

Lead—CP wire, also known as tinned copper clad steel wire, has high conductivity, good bending performance, and weldability, - a and is a bridge for internal energy transmission to the outside.

引线—CP 线，也叫做镀锡铜包钢线，具有高导电率，良好的折弯性能和可焊性，是内部能量向外部传输的桥梁。

Rubber plug—Made of elastomer material, which prevents short-circuiting between the terminals and the housing, and has a sealing and insulating effect, preventing the electrolyte from leaking out and evaporating.

胶塞—由弹性体材料制成，可防止端子与外壳之间短路，并具有密封和绝缘作用，防止电解液渗漏和蒸发。

Product size 产品尺寸:

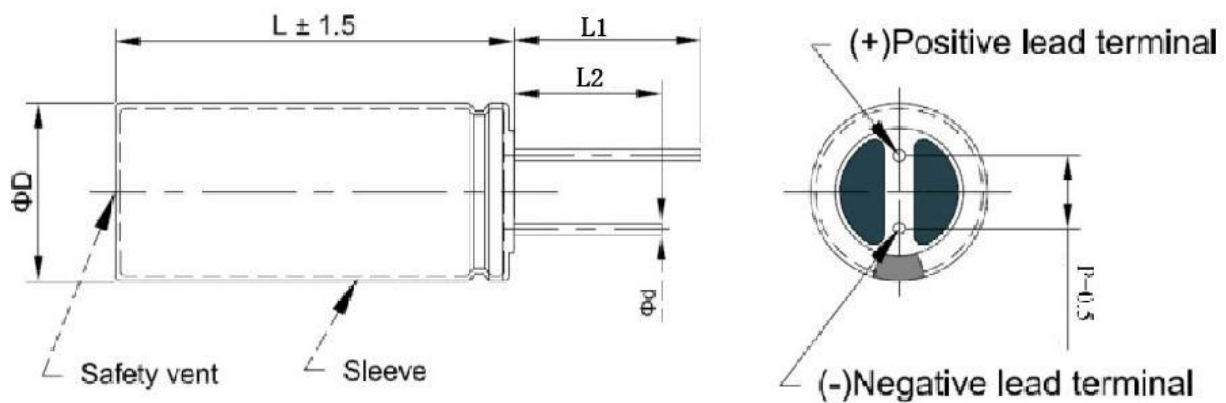

Series 型号系列	ΦD (mm)	L (mm)	L1 (mm)	L2 (mm)	Φd (mm)	P (mm)	Weight 重量(g)
CKBB1840	18+1.5 Max	40±1.5	27.5±1.0	25.0+1.0	0.8±0.1	7.5±0.5	≤22.0

Product Technical Index 产品技术指标

Series 序号	Merits 特性	Specifications 规格	Note 备注
1	Working Temperature 工作温度	-40°C~65°C	
2	Work Voltage 推荐工作电压区间	2.5~4.0V	
3	Min Voltage 最低电压	2.5V	
4	Surge voltage 浪涌电压	4.2V	
5	1C Test current 1C 测试电流	650mA	
6	Rated capacity 额定容量(@25±3°C)	650mAh/1300F	4.2V-2.5V
		550mAh	4.0V-2.5V
	Tolerance 电容公差	-20%~+20%	
7	Equivalent capacity 等效容量	650.0mAh	
8	DCR 直流内阻	≤90mΩ	4.2V@25±3°C, 10msec
9	ACR 交流内阻	≤35mΩ	1kHz, 3.6V
10	Max discharge current 最大放电电流	Continuous 连续放电	6.0A
		Pulse (1sec) 3.8V 脉冲	20.0A
11	Max charge current 最大充电电流	6.0A	
12	Cycling performance 循环寿命	≥8000 次	
13	Mass (g) 标准重量	≤22.0	
14	Optimum storage condition 最佳存储环境	+10C~50°C 60%RH 或以下	

Technical Information 性能特性

Series 序号	Project 项目	Properties 性能
1	High-low temperature properties 高低温特性	Capacitance (-20°C): $\geq 70\%$ of initial measured value 电容(-20°C): \geq 初始测量值的 70% Internal resistance (-20°C): ≤ 10 times the initial specified value 内阻(-20°C): \leq 初始规定值的 10 倍 Capacitance (+65°C): $\geq 70\%$ of initial measured value 电容(+65°C): \geq 初始测量值的 70% Internal resistance (+65°C): ≤ 2 times the initial specified value 内阻(+65°C): \leq 初始规定值的 2 倍
2	High temperature and high humidity storage properties 高温高湿存储特性	Capacitance: $\geq 70\%$ of initial measured value 电容: \geq 初始测量值的 70% Internal resistance: ≤ 2 times the initial specified value 内阻: \leq 初始规定值的 2 倍
3	Charge/discharge cycling properties 充电/放电循环特性	Capacitance: $\geq 70\%$ of initial measured value 电容: \geq 初始测量值的 70% Internal resistance: ≤ 4 times the initial specified value 内阻: \leq 初始规定值的 4 倍

Electrochemical performance test 电化学性能测试

Testing Conditions 测试条件

This specification followed the standard testing criteria: 1 atm, 25±3°C and a relative humidity < 65%.

本产品规格书标准测试条件为：标准大气压下，温度 25±3°C，相对湿度小于 65%。

Testing Demands for Tools 测量工具要求

(1) Size: Need to use JIS B 7503 / KS B 5206 (Micrometer), JIS B 7507 / KS B 5203-2 Verniercaliper)

JIS B 7502 / KS B 5205 / KS B 5202(External micrometer) or other same precision grade devices.

尺寸：必须使用 JIS B 7503 / KS B 5206（千分尺），JIS B 7507 / KS B 5203-2（游标卡尺）

JIS B 7502 / KS B 5205 / KS B 5202（外部千分尺）或精度等级相同的仪表。

(2) DC Voltmeter: Need to use 0.2 grade type JIS C 1102 / KS C 1303-2(Electric Indicator) or much

high precision devices, its internal resistance should over $10M\Omega$.

直流电压表：必须使用 0.2 级的 JIS C 1102 / KS C 1303-2（电动指示仪）度相同或更高等级的仪表，其输入电阻超过 $10M\Omega$ 。

(3) DC Ammeter and AC Voltmeter: Need to use 0.2 grade type JIS C 1102 / KS C 1303-2(Electric Indicator) or much high precision devices.

直流电流表和交流电流表：必须使用 0.2 级的 JIS C 1102 / KS C 1303-2（电动指示仪）度相同或更高等级的仪表，其输入电阻超过 $10M\Omega$ 。

8.3 Test for Capacitance 容量测试

At $25\pm 3^{\circ}\text{C}$, discharge the battery with a constant current I to 2.5V before testing. Charge the product at $1C$ to the set voltage of U_R , Constant voltage charging for 30 min and cut off the current. Then, discharge the product at $1C$ to 2.5V. After standing for 30 seconds, repeat the above process again, and take the capacity value after the third discharge as the capacity value of the product.

在 $25\pm 3^{\circ}\text{C}$ 条件下，在测试前，先将电池用恒定电流 I 放电至 2.5V。将产品以 $1C$ 充电至设定电压 U_R 后恒压充电 30min，紧接着，以 $1C$ 电流将产品放电至 U_1 。静置 30s 后，再次重复上述过程，取第 3 次放电后的容量值为产品的容量值。

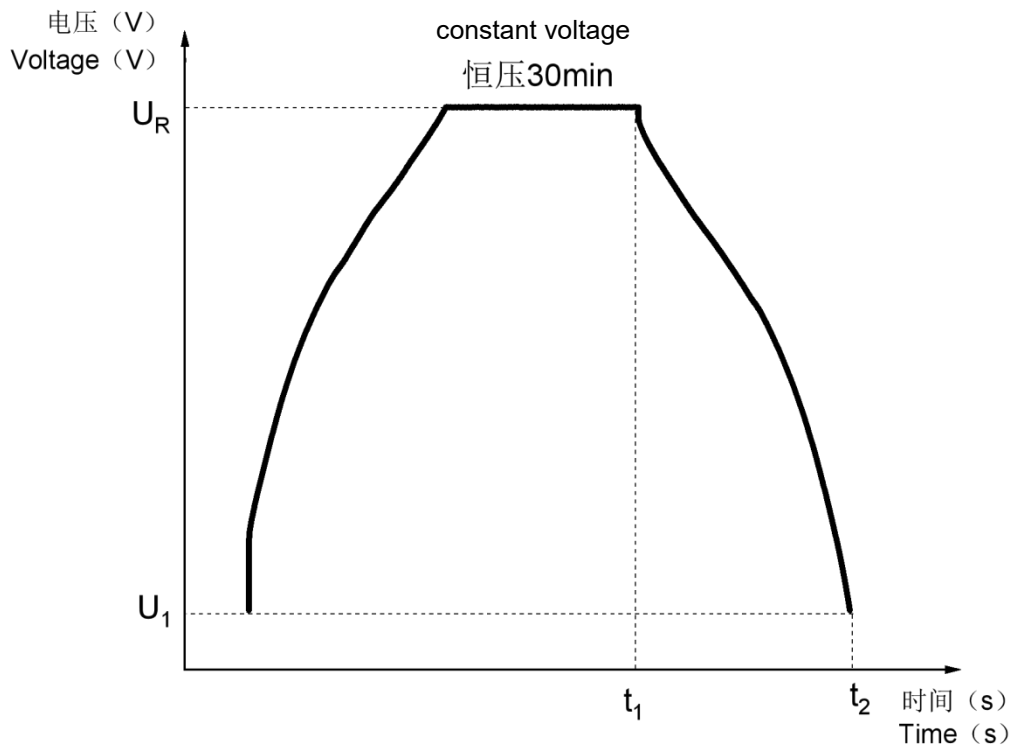

Fig1. Charge/Discharge curves for Sample

图 1 样品的充放电曲线

$$C = I * (t_2 - t_1) / (U_R - U_1)$$

The formula: 公式中:

I—Discharge Current 1C(mA)

I—:放电电流 1C(mA);

U_R—Voltage before test:U_R=4.2(V)

U_R—测量初始电压:U_R=4.2(V);

U₁—Voltage after test:U=2.5(V)

U₁—测量结束电压:U₂=2.5(V);

t₁—Discharge time from U_R

t₁—从 U_R 开始放电时间

t₂—Timing from discharging to U₁;

t₂—放电开始到测量结束电压 U₁ 的时间(s);

Direct current Resistance Test (DCR) 直流内阻测试

Charge the Li-ion capacitor at constant current (I) at room temperature to 4.2V. Charge at 4.2V constant voltage for 30 minutes, and record the end moment as t₀. Discharge the capacitor again at constant current (I) to 2.5 V, and record the voltage U at t₀+10 ms. Repeat the above steps 3 times, and calculate the DC internal resistance of the 3rd cycle as the DC internal resistance of the Li-ion supercapacitor according to the following formula.

在室温下将锂离子电容器恒流(I)充电至 4.2V，并恒压充电 30min，将结束时刻记录为 t_0 。再以恒定电流(I)放电至 2.5V，记录 t_0+10ms 时的电压 U。重复上述步骤 3 次，根据下述公式计算第 3 次循环的直流内阻作为锂离子超级电容器的直流内阻 (DCR)。

$$DCR = (4.2-U)/I$$

Alternating current Resistance Test (ACR)交流内阻测试

Charge the cell to 3.6V and keep this voltage for 30min, then using the AC Internal resistance to test its AC Resistance at 1kHz.

常温下，将单体充电至 3.6V 并恒压充电 30min 后，在 1kHz 条件下，采用交流阻抗仪进行交流内阻测试。

High-low temperature properties 高低温性能测试

Based on the 《Test for Capacitance》 charging the cell to 3.8V at $25\pm 3^\circ\text{C}$, and move the cell to a fixed temperature ($-20\pm 3^\circ\text{C}$, $25\pm 3^\circ\text{C}$, $65\pm 3^\circ\text{C}$), meantime charge the cell by constant voltage for 1h. After this, the cell's capacitance was tested At a current value of 1C.

$25\pm 3^\circ\text{C}$ 条件下，将单体参照《容量测试》方式充电至 4.2V 后，紧接着将其转移至设定温度(设定温度分别为 $-20\pm 3^\circ\text{C}$ ， $25\pm 3^\circ\text{C}$ ， $65\pm 3^\circ\text{C}$)条件下，在 4.2V 持续稳压的同时将样品放置 1h。此后，将产品以 1C 放电电流要求在设定温度条件下进行容量测试。

High temperature and high humidity storage properties 高温高湿存储特性

At a current value of 1C, and the charge 1h at constant voltage condition at room temperature. After this, put the cell to $60\pm 3^\circ\text{C}$ 、 $90\pm 3\%$ RH conditions to storage 1000h. Finally, cooling the cell at room temperature and check its electrochemical properties by 《Test for Capacitance》 and 《est for AC Resistance》.

常温条件下，将产品以 1C 电流充电至 3.6V 并恒压充电 1h，后将其放置在 $60\pm 3^\circ\text{C}$ 、 $90\pm 3\%$ RH 的条件下存储 1000h。接着将其冷却至室温，并参照《容量测试》和《交流内阻测试》方法测试样品的电化学特性。

Charge/discharge cycling properties 充/放电循环性能测试

At a current value of 5C, charge the cell to 4.0V at room temperature, and the discharge it to 2.5V at the same current. Once cycling 100000times, re-checking its electrochemical properties by 《Test for Capacitance》 and 《Test for AC Resistance》 .

常温条件下，以 5C 电流将单体充电至 4.0V，紧接着将其以该电流放电至 2.5V 循环 8000 次后，参照《容量测试》和《交流内阻测试》要求测量其电化学特性。

Safety Test 安全测试

Satus of the Cell as of Ex-factory 电芯出厂状态

The battery cell should ensure transportation within the range of 3.3V to 3.65V (30-55%SOC).
电芯应保证在 3.3V 至 3.65V(30~55%SOC)范围内转运。

Precautions 注意事项

During Operation 使用规范

- ❖ Working temperature of LIC should not exceed the upper and lower limits of the rated temperature.
锂离子电容器的使用温度不宜超过额定温度上限或下限。
- ❖ LIC should be used at rated voltage.
锂离子电容器应在额定电压区间下使用。
- ❖ Check the polarity of LIC before power on. No reverse connecting.
锂离子电容器在使用之前请确认极性，禁止反接。
- ❖ Keep LIC away from heat. The temperature has a big influence on the working life of LIC.
外界环境温度对锂离子 电容器的寿命具有重要影响，请远离热源。
- ❖ No direct contacting with water, oil, acid or alkaline.
锂离子电容器请勿直接接触水、油、酸或碱。
- ❖ No crushing, nail penetrating or disassembling LIC.
请勿挤压、钉刺或拆解锂离子电容器。

- ❖ No discarding. Dispose LIC based on the State Environmental-protection Standard.
- ❖ The cell embraced constant voltage before shipment, therefore, the short circuit should be extremely forbidden.

本产品发货前已具有一定电压值，使用过程中切勿使正负极端子短路

储存 Storage

- ❖ No storage in a condition with a relative humidity exceeding 85% or
- ❖ with toxic gases. It is easy to cause the damage and corrosion of the terminals and case, resulting in disconnection.

锂离子电容器不可处于相对湿度为 85%以上或含有有毒气体的场所，该种环境下引线及壳体易受潮及腐蚀，导致锂离子电容器断路。

- ❖ For Long-term storage, place LIC in a well-ventilated condition at 10 to 55°C, with a relative humidity below 60%. Forbidden to sun directly.

锂离子电容器若需长期储存，请在温度 10~55°C，相对湿度 60%以下，通风良好的场所存放，严禁暴晒。

Shipment 运输

The capacity of delivery cell is approximately at 45%-55% of charging. It is not specified more than 45%-55% capacity remain at customer, because of self-discharge. During transportation, keep the cell from acutely vibration, impacting, solarization, drenching.

出货电芯处 45%-55%充电状态，由于电芯存在自耗，运送到客户端的电芯无法完全保证 45%-55%荷电量。运输过程应防止剧烈振动、冲击、日晒雨淋。