



1. Capacitor characteristics and applications

1.1 FEATURES

- Size specification serial, suitable for surface mounting elements of hybrid integrated circuit or printed circuit;
- It has the characteristics of low loss, high electrical capacity stability and high reliability;
- Suitable for all kinds of equipment in the high frequency circuit, amplification circuit;

1.2 Main performance indicators

- Temperature coefficient: NPO: $0 \pm 30\text{ppm}/^\circ\text{C}$
- Capacitance drift: no more than $\pm 0.2\%$ or $\pm 0.05\text{ pF}$, take the larger
- Loss angle tangent: not exceeding 0.15% at a frequency of 1 MHz / 1 KHz
- Insulation resistance (25°C): $100000\text{M } \Omega$
- Medium voltage resistance (test surge current does not exceed 50mA): 2.5 UR
- Operating temperature: $-55\sim 125^\circ\text{C}$

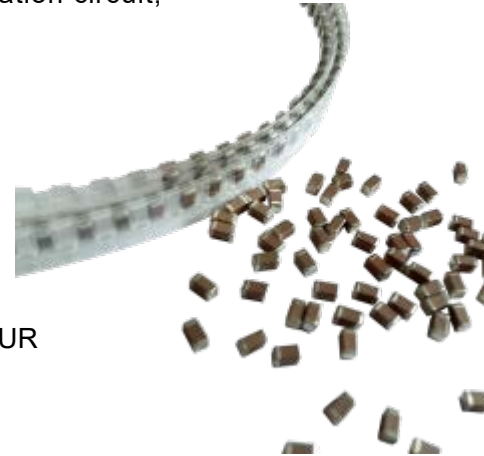

2. Product model naming Specification

CCDA	0505	N	4R7	B	1H	Z	M
model	dimensions	characteristic	rated capacitance	Allowable deviation of the electrical capacitance	rated voltage	exit	failure rate level
CCDA: Class 1 porcelain dielectric capacitor	0505 1111 1812	N: $0 \pm 30\text{ppm}/^\circ\text{C}$	The first and second digits represent significant numbers, and the last digit is the number of zeros that follow	B: $\pm 0.1\text{pF}$ C: $\pm 0.25\text{pF}$ D: $\pm 0.50\text{pF}$ J: $\pm 5\%$ K: $\pm 10\%$	1H: 50V 2A: 100V 2R: 150V 2D: 200V	Base metal shield tin (tin / lead alloy with at least 3% lead)	$\leq 1.0\%/1000\text{h}$



3. Product dimensions

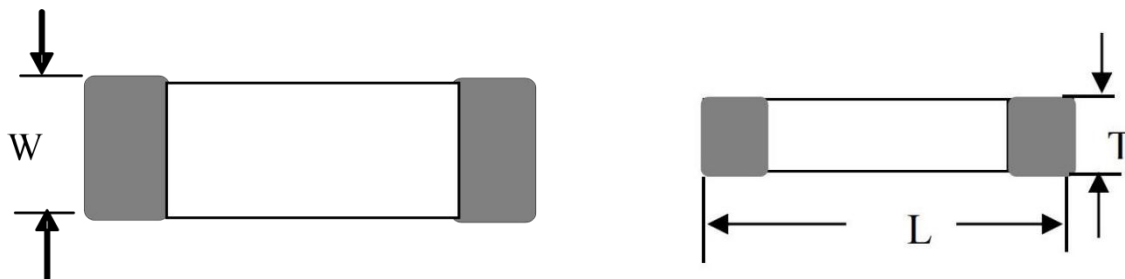

model		Dimensions (mm)		
The British system said	Metric representation	L	W	T _{max}
0505	1212	1.40 ^{+0.38} / _{-0.25}	1.40±0.38	1.45
1111	2828	2.79 ^{+0.51} / _{-0.25}	2.79±0.38	2.59
1812	4532	4.50±0.40	3.20±0.30	3.10

Note: Products that meet customer requirements can be designed according to the special requirements of customers.

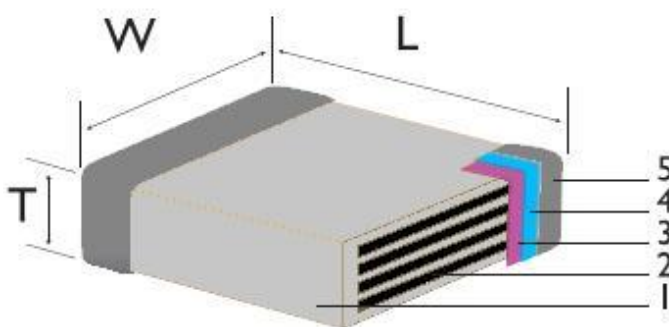

order number	name
1	ceramic dielectric
2	inner electrode
3	External electrode
4	nickel dam
5	Lead tin layer



4. Capacity range

4.1 0505 Specification capacity value table

0505 specification and value table

Tolerance code	Tolerance (pF)	accuracy	Maximum direct current operating voltage (V)	Tolerance code	Tolerance (pF)	accuracy	Maximum direct current operating voltage (V)	Tolerance code	Tolerance (pF)	accuracy	Maximum direct current operating voltage (V)	Capacity value code	Capacity value (pF)	accuracy	Maximum direct current operating voltage (V)		
0R2	0.2	B,C	200					9R1	9.1	B,C							
0R3	0.3			1R9	1.9								510	51			
0R4	0.4			2R0	2								560	56			
					2R1	2.1			100	10			620	62			
					2R2	2.2			110	11			680	68			
					2R4	2.4			120	12			750	75		150	
					2R7	2.7			130	13			820	82			
0R5	0.5	B,C, D			3R0	3			150	15			910	91			
0R6	0.6			3R3	3.3					160	16		101	100			
0R7	0.7			3R6	3.6					180	18					F,G,	
0R8	0.8			3R9	3.9			B,C, D	200	200	20	F,G,				J,K,	
0R9	0.9			4R3	4.3					220	22	J,K,		111	110	M	50
1R0	1			4R7	4.7					240	24	M		121	120		
1R1	1.1			5R1	5.1					270	27						
1R2	1.2			5R6	5.6					300	30						
1R3	1.3			6R2	6.2					330	33						
1R4	1.4			6R8	6.8					360	36						
1R5	1.5			7R5	7.5					390	39						
1R6	1.6			8R2	8.2					430	43						
1R7	1.7									470	47						
1R8	1.8																



4.2 1111 Specification capacity value table

1111 Specification capacity value table

Tolerance code	Tolerance (pF)	accuracy	Maximum direct current operating voltage (V)	Tolerance code	Tolerance (pF)	accuracy	Maximum direct current operating voltage (V)	Tolerance code	Tolerance (pF)	accuracy	Maximum direct current operating voltage (V)	Capacity value code	Capacity value (pF)	accuracy	Maximum direct current operating voltage (V)
0R2	0.2	B,C	200	2R4	2.4	B,C, D	200	200	20	F,G, J,K, M	200	151	150	F,G J,K, M	200
0R3	0.3			2R7	2.7			220	22			161	160		
0R4	0.4			3R0	3			240	24			181	180		
0R5	0.5	B,C, D	200	3R3	3.3	F,G, J,K, M	200	270	27	F,G, J,K, M	200	201	200	F,G J,K, M	200
				3R6	3.6			300	30			221	220		
				3R9	3.9			330	33			241	240		
				4R3	4.3			360	36			271	270		
				4R7	4.7			390	39			301	300		
				5R1	5.1			430	43			331	330		
				5R6	5.6			470	47			361	360		
				6R2	6.2			510	51			391	390		
				6R8	6.8			560	56			431	430		
				7R5	7.5			620	62			471	470		
1R0	1	B,C, D	200	8R2	8.2	F,G, J,K, M	200	680	68	F,G, J,K, M	200	100	100	F,G J,K, M	200
1R1	1.1			9R1	9.1			750	75			110	110		
1R2	1.2			100	10			820	82			120	120		
1R3	1.3			110	11			910	91			130	130		
1R4	1.4			120	12			101	100			140	140		
1R5	1.5			130	13			111	110			150	150		
1R6	1.6			150	15			121	120			160	160		
1R7	1.7			160	16			131	130			180	180		
1R8	1.8			180	18										
1R9	1.9														
2R0	2														
2R1	2.1														
2R2	2.2														



4.3 1812 Specification capacity value table

1812 Specification value table

Tolerance code	Tolerance (pF)	accuracy	Maximum direct current operating voltage (V)	Tolerance code	Tolerance (pF)	accuracy	Maximum direct current operating voltage (V)	Tolerance code	Tolerance (pF)	accuracy	Maximum direct current operating voltage (V)	Capacity value code	Capacity value (pF)	accuracy	Maximum direct current operating voltage (V)		
0R5	0.5			4R3	4.3	B,C,D						241	240				
				4R7	4.7							330	33			271	270
				5R1	5.1							360	36			301	300
				5R6	5.6							390	39			331	330
				6R2	6.2							430	43			361	360
				6R8	6.8							470	47			391	390
				7R5	7.5							510	51			431	430
				8R2	8.2							560	56			471	470
				9R1	9.1							620	62				
				1R3	1.3											680	68
1R5	1.5	B,C,D	200	100	10		200	750	75	F,G,		561	560	F,G	150		
1R6	1.6			110	11			820	82	J,K,		621	620	J,			
1R8	1.8			120	12			910	91	M		681	680	K,			
2R0	2			130	13			101	100			751	750	M			
2R1	2.1			150	15			111	110			821	820				
2R2	2.2			160	16			121	120								
2R4	2.4			180	18			131	130								
2R7	2.7			200	20			151	150			911	910				
3R0	3			220	22			161	160			102	1000				
3R3	3.3			240	24			181	180			112	1100				
3R6	3.6	270	27	201	200		122	1200									
3R9	3.9	300	30	221	220												



5. Technical requirements and test conditions

5.1 Conventional electrical performance

project	technical specifications	test method				
operating temperature range	$(-55 \sim +125)^{\circ}\text{C}$					
surface	no significant defect	eyeballing				
Electrostatic capacity of Capacitance	Within the specification error range	nominal capacity	Test frequency	test voltage	ambient temperature	
		$\leq 1000\text{pF}$	1MHz ($\pm 10\%$)	$(1.0 \pm 0.2)\text{V}_{\text{rms}}$	$(25 \pm 2)^{\circ}\text{C}$	
		$> 1000\text{pF}$	1KHz ($\pm 10\%$)			
loss tangent (DF)	The frequency is Not at 1 MHz / 1 KHz Over 0.15%	Test method: the same as the "static electricity capacity"				
insulation resistance (I.R). Insulation Resistance	$\geq 100000\text{M}\Omega$	rated voltage	test voltage	testing time	Charge and discharge current	environment
		$U_r < 1000\text{V}$	U_r	$(60 \pm 5)\text{ sec}$	$\leq 50\text{mA}$	temperature $(25 \pm 2)^{\circ}\text{C}$ Humidity was $< 75\%$
		$U_r \geq 1000\text{V}$	1000V	$(60 \pm 5)\text{ sec}$	$\leq 50\text{mA}$	
Electric resistance strength of the medium (D.W.V).	Media should not be broken down or damaged	rated voltage	test voltage	duration	Charge and discharge current	
		All voltage	$2.5U_r$	5 Seconds	$\leq 50\text{mA}$	
Capacity temperature coefficient or temperature characteristics	C 0G : $(0 \pm 30)\text{ ppm}/^{\circ}\text{C}$	The following temperature order, 30min after temperature stability (ΔC to T 3)				
		step	temperature ($^{\circ}\text{C}$)			
		T 1	25 ± 2			
		T 2	Lower limit Category temperature (-55 ± 3)			
		T 3	25 ± 2			
		T 4	Upper limit Category temperature (125 ± 2)			
Solder ability	surface	No visible damage, injury, on tin rate of 95%	Absolve the capacitor in ethanol and rosin (25% weight) solution, remove the temperature at $(80 \sim 120)^{\circ}\text{C}$ (10-30) seconds, and soak the solder solution.			
			Tin immersion temperature: $(245 \pm 2)^{\circ}\text{C}$; tin immersion speed: $(25 \pm 0.25)\text{ mm / sec}$			
			Tin immersion time: $(5 \pm 0.5)\text{ sec}$			
remarks: When testing the dielectric power resistance strength of the capacitor, in order to eliminate the influence of the external environment, when the test voltage exceeds 2000 Vdc, then the capacitor should be soaked in insulating oil for testing.						



5.2 Quality consistency test

Quality consistency test is A group A test, consisting of the following table and performed in the order shown. Equal MIL-PRF-55681/4/5

divide into groups	inspecting item	Requires the chapter number	Test method chapter number	sampling plan
A divide into groups	Voltage treatment	3.8 in ZZR-Q / CT 20003-2018	4.5.3 in GJB 192B-2011	100%
A divide into groups	Insulation resistance (125°C)	3.11 in ZZR-Q / CT 20003-2018	4.5.6 in GJB 192B-2011	In accordance with GJB 192B-2011 Table 6
A divide into groups	Visual and mechanical inspection	3.3 in ZZR-Q / CT 20003-2018, .4.1 3, 3.28 , 3.29	4.5.2 in GJB 192B-2011	In accordance with GJB 192B-2011 Table 6
A divide into groups	solder ability	3.15 in ZZR-Q / CT 20003-2018	4.4.2 in GJB 192B-2011	13 samples, and 0 failed

6.2.1 A1 group —, voltage treatment

100% test, requirements: when appropriate, can select voltage processing screening.

Test temperature: 125_{0}^{+4} °C ;

Test time: 96_{0}^{+4} hour;

Applied voltage: $2U_R$

6.2.2 A2 block — Insulation Resistance (125°C)

Sampling test according to the requirements in Table 6 in GJB 192B-2011,

Test temperature: 125_{0}^{+4} °C ;

test voltage U_C : $U_C = U_R (U_R < 1000V)$;

Applied voltage time: (60 ± 5) seconds.

6.2.3 A3 group — appearance and mechanical inspection

Sampling test according to the requirements in Table 6 in GJB 192B-2011, The size suitable for the gauge inspection shall be inspected;

Visual inspection of the sheet capacitor under a microscope (10 times magnification): No cracks and cracks, layering, and electrode exposure are allowed on the surface of the capacitor.

6.2.4 A4 grouping — soldability

Draw 5 products from each batch;

Test conditions: the lead end of the capacitor continues in the welding tin groove of (245 ± 2) °C (5 ± 0.5) S;

Requirements: After testing, perform a visual inspection with a 10 x magnification lens. The surface of the lead end should be 95% evenly stained with tin, tin layer continuous. The remaining 5% allows only very small pinholes and no defects with solder immersion, but should not be concentrated in one area.



6. Notes for use

Notes for MLCC

1. Notes before use:

The MLCC chip may be damaged under the harsh working environment or the external mechanical overpressure described in the relevant instructions in this admission letter, so first considering the relevant conditions in this admission letter.

2. The recommended layout of the PC board design

2.1 The amount of solder used will affect the ability of the chip to resist mechanical stress, which may lead to the breakage or cracking of MLCC. Therefore, when designing the substrate, we must carefully consider the size and configuration of the welding pad, which has a decisive role in the amount of the solder composed of the substrate.

2.2 When designing the position of the pad and SMD MLCC, the stress shall be reduced to the lowest point, and the MLCC shall be installed in the least affected position on the PC plate.

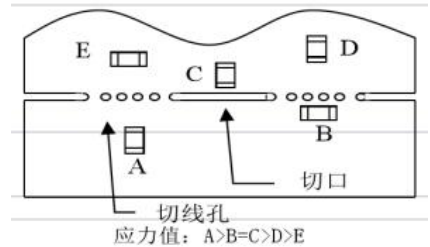

3. Automatic installation should consider the problems

If the suction tube drops beyond the minimum limit, it will produce excessive pressure on the MLCC, which will cause the MLCC rupture. When lowering the tube, pay attention to the following points:

3.1 After correcting the deviation of the PC plate, the low limit of the suction tube should be adjusted to the surface horizontal position of the PC plate.

3.2 The suction pressure shall be adjusted between 1 and 3N.

3.3 In order to reduce the deformation degree of the PC plate caused by the impact force of the suction, the support nail shall be placed under the PC plate.

4. Welding

4.1 MLCC is a combination of ceramic and metal. As a ceramic body, especially the large size ceramic body, its thermoplasticity is poor, the response to heat is relatively slow, by the cold and hot, the ceramic body is easy to crack. It is recommended to conduct continuous preheating for more than 1 minute before welding.

The interior of the 4.2 MLCC is a metal electrode, which is very thermoplastic and responds responsive to heat. Therefore, in the case of heat, the metal part and the ceramic part must have a certain degree of inconsistent expansion, resulting in internal stress, easy to cause porcelain cracking. It is recommended to conduct continuous preheating for more than 1 minute before welding.

4.3 For manual welding, the maximum diameter of the tip with constant temperature iron is 1.0mm and the maximum power is 25 watts; the iron cannot directly touch the MLCC element.

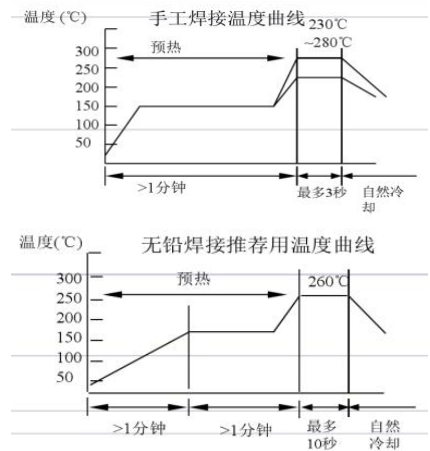

5. Cleaning

5.1 The temperature difference between the components and the cleaning process shall not be greater than 100°C.

5.2 In the case of ultrasonic cleaning, if the output power is too large, the PC plate will withstand excessive vibration, which will cause the MLCC or welding point to crack, or reduce the strength of the end electrode. Therefore, special attention should be paid to the following points:

Ultrasonic output: less than 20W / L; ultrasonic frequency: less than 40 KHz; ultrasonic cleaning time: 5 minutes or less

6. Cut the PC plate

6.1 After installing the MLCC and other components, note that any force should be applied to the PC board. MLCC cannot tolerate excess

6.2 The segmentation of the board cannot be divided by hand, and appropriate equipment should be used.

7. Storage method

To maintain the weldability of the end electrodes and to keep the packaging materials in good condition, the recommended storage conditions are as follows:

Storage temperature: (5-40) °C; storage relative humidity: (20-70)% RH

The MLCC end weldability decreases over time even when stored under ideal storage conditions, so the MLCC should be used within 6 months from the date of shipment.



7. Product packaging

7.1 bags in bulk

specifications	bulk	remarks
0505	5000	Packaging form and quantity can be determined according to the customer's requirements
1111	2000	
1812	50	

7.2 Paper tape packaging

7.2.1 Paper tape coil structure

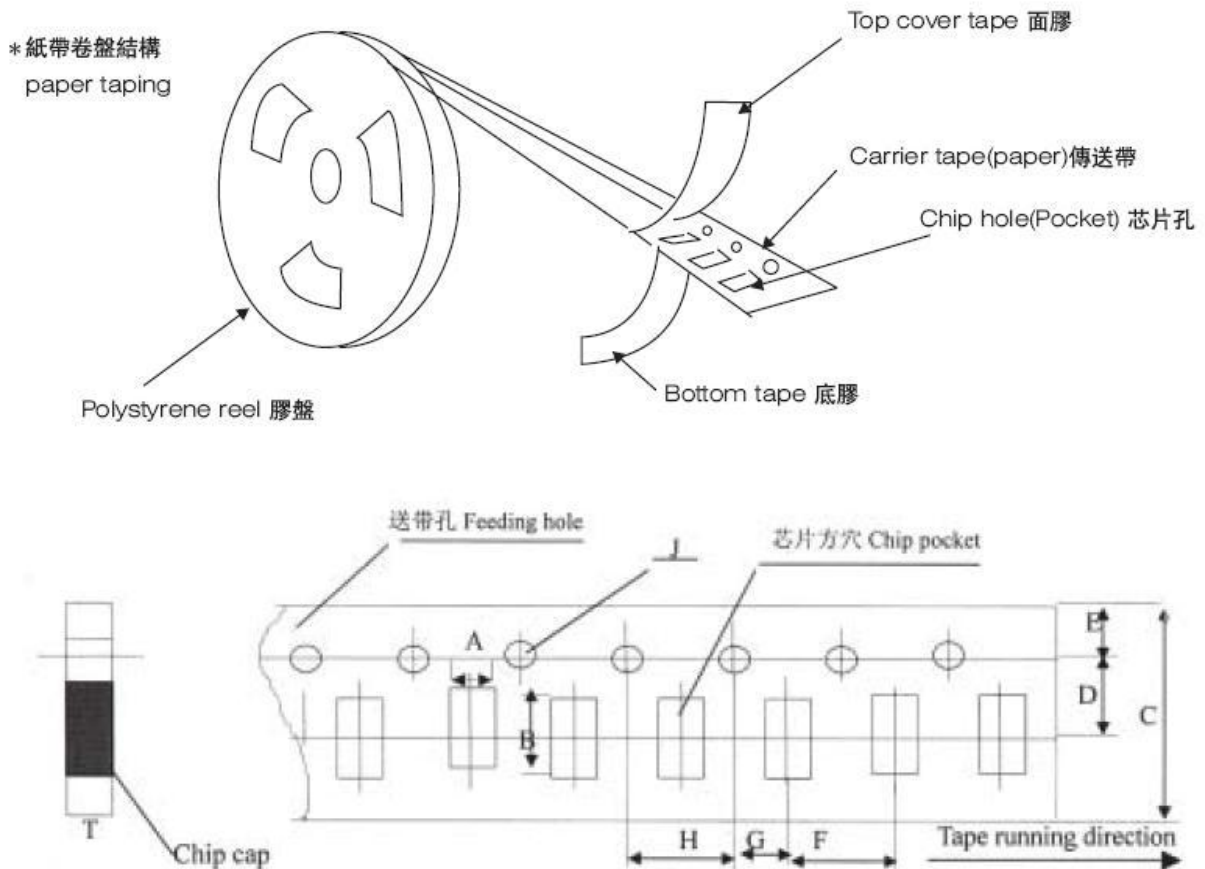

7.3 Plastic tape packaging

7.3.1 Plastic tape coil structure

*塑膠卷盤結構
embossed taping

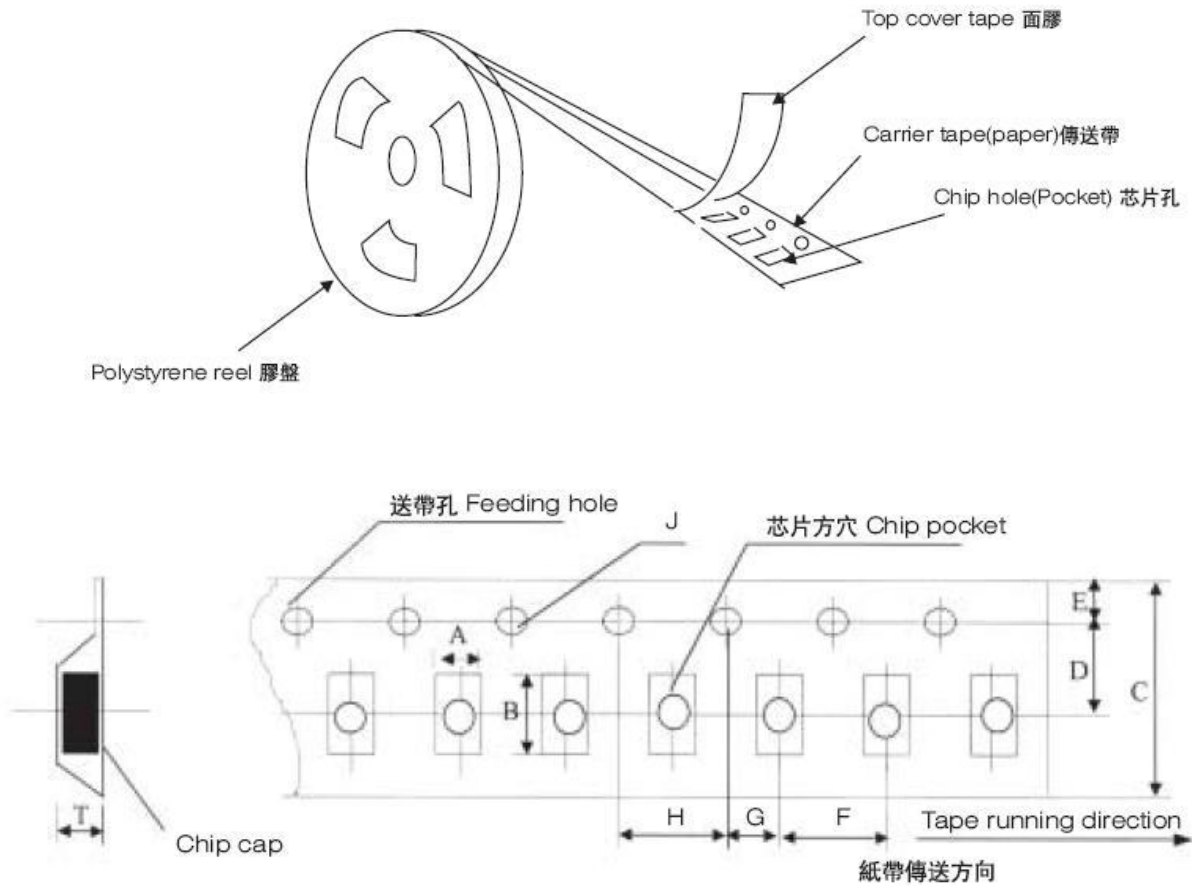

7.4 Front and rear structure of the conveyor belt

*傳送帶的前後結構

Structure of leader part and end part of the carrier paper

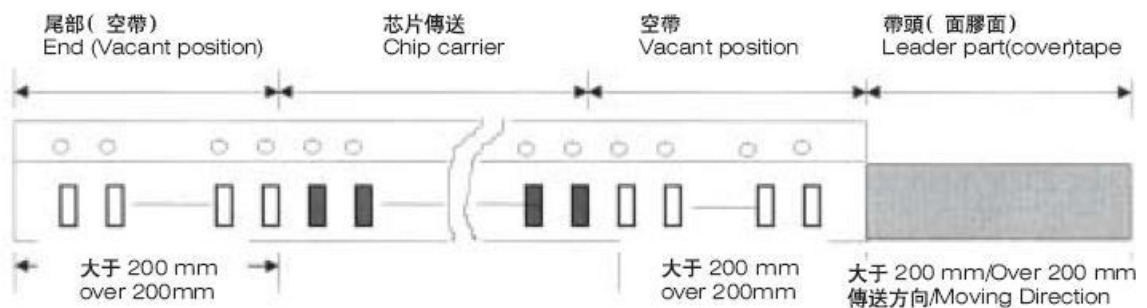



7.5 Reel dimensions

*卷盘尺寸 Reel Dimensions (unit:mm)

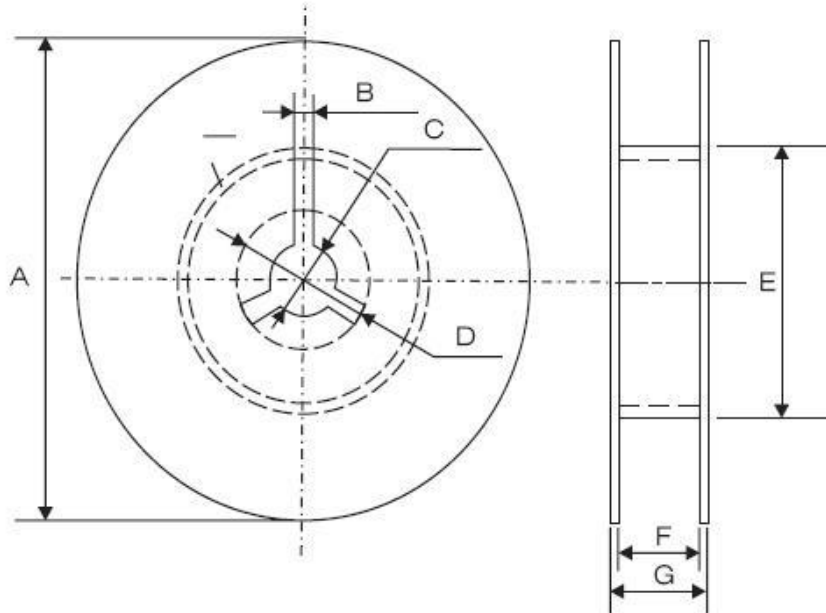

A	B	C	D	E	F	G
Φ 178.00±2.00	3.00	Φ13.00±0.50	Φ21.00±0.80	Φ 50.00 or greater	10.00±1.50	12Max
Φ 330.00±2.00	3.00	Φ13.00±0.50	Φ21.00±0.80	Φ 50.00 or greater	10.00±1.50	12Max

7.6 Ribbon preparation method

8.6.1 The belt of the packaging capacitor is wound clockwise. When the belt is pulled from the top to the down direction, the transfer hole is on the right side of the belt.

8.6.2 For the front end of the strip, leave at least 5 spaced strips.

8.6.3 When compiling the belt, the lead belt part or blank part must be reserved according to the figure below.

8.6.4 The number of product errors in the installation of the disk must be less than 0.1% of the number or 1 per disk, discontinuous errors.

8.6.5 The upper and lower tape shall not exceed the edge of the tape and shall not block the transfer hole.

8.6.6 The cumulative error of the transmission hole is 10 spacing: ± 0.3 mm.

8.6.7 The stripping moment of the upper tape shall be within 0.1 to 0.7 Newton as shown in the following below.

